

Features of the power supply:

- power output 0,8A/13,8VDC^{*}
- universal AC input voltage range 90÷264V
- high efficiency 77%
- standby power <0,3W
- efficiency level: V
- IP 67 case
- protections:
 - SCP short-circuit protection
 - overvoltage protection (AC input)
 - overload (OLP)
- warranty – 2 year from the production date

1. Technical description.

1.1. General description.

Stabilized DC power supply is intended for supply CCTV cameras that require stabilised voltage of **13,8V DC**. The unit is protected against short-circuit and overload.

1.2. Technical parameters.

Supply voltage	90 ÷ 264V AC 50÷60Hz
Current consumption	0,125A@230V AC max.
Supply power	11W max.
Efficiency	77%
Output voltage	13,8V DC
Output current $t_{AMB}<30^{\circ}C$	0,8A instantaneous current - refer to graph 1.
Output current $t_{AMB}=40^{\circ}C$	0,5A - refer to graph 1.
Ripple voltage	100mV p-p max.
Short-circuit protection SCP	electronic, automatic recovery
Overload protection OLP	105-150% of power supply, automatic recovery
IP protection class	IP67
Operation conditions	temperature 0 °C÷40 °C relative humidity 20%...90%
Dimensions (LxWxH)	50 x 48 x 25 [mm]
Net/gross weight	0,10kg / 0125kg
Protection class PN-EN 60950-1:2007	II (second)
Length of DC cable	0,3 m
Length of AC cable	0,3 m
Storage temperature	-20°C...+60°C

* In order to extend the life of the power supply, the load current of 0,5A is recommended.

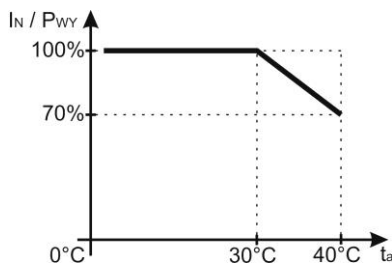

Graph 1.
Relation between output current and ambient temperature (instantaneous load).

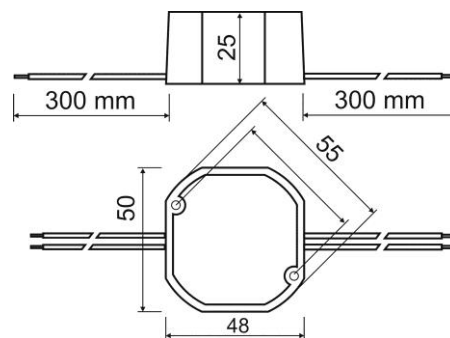

Fig.1. Dimensions of power supply.

* Refer to graph 1

1.3. Accessories.

For the power supplies are available accessories - fuse blocks and cable adapter. For details –visit www.pulsar.pl.

2. Installation.

2.1. Requirements.

The power supply shall be mounted by the qualified installer having appropriate (required and necessary for a given country) permissions and qualifications for connecting (operating) low-voltage installations. The power supply shall be mounted in closed rooms, according to the environment class II, of the normal air humidity (RH=90% max.) and the temperature within the range from 0°C to +40°C.

In order to fulfill LVD and EMC requirements the rules for power supplies, encasing and shielding shall be observed according to application.

2.2. Installation procedure.

1. Fit the power supply inside the box or other device.
2. Connect the DC output to the load or to the terminal block.
3. Connect the power supply to the AC line.
3. After tests and operation control are performed, close installation box, case etc. and switch on the power (230V AC).

3. Maintenance.

Any and all maintenance operations may be performed following the disconnection of the power supply from the power network. The power supply does not require any specific maintenance procedures, however, in the case of significant level of dust, it should be cleaned with the compressed air.



WEEE MARK

According to the EU WEE Directive – It is required not to dispose of electric or electronic waste as unsorted municipal waste and to collect such WEEE separately.

Pulsar

Siedlec 150, 32-744 Łapczyca, Poland
Tel. (+48) 14-610-19-40, Fax. (+48) 14-610-19-50
e-mail: biuro@pulsar.pl, sales@pulsar.pl
http:// www.pulsar.pl, www.zasilacze.pl